

Barudan

HIGH SPEED AUTOMATIC EMBROIDERY MACHINE

MODEL KS/KY Control

PARTS LIST

BARUDAN CO., LTD.

20 Tsukagoshi Josuji,
Ichinomiya-city, Aichi-pref., Japan
TEL <81> 586-76-1137 FAX <81> 586-77-1499
<http://www.barudan.co.jp/>

株式会社 **バルダン**

〒491-0004 愛知県一宮市定水寺塚越20番地
TEL (0586) 76-1137 (代) FAX (0586) 77-1499
<http://www.barudan.co.jp/>

11A-1-1 Control A (KS)
制御A (KS)

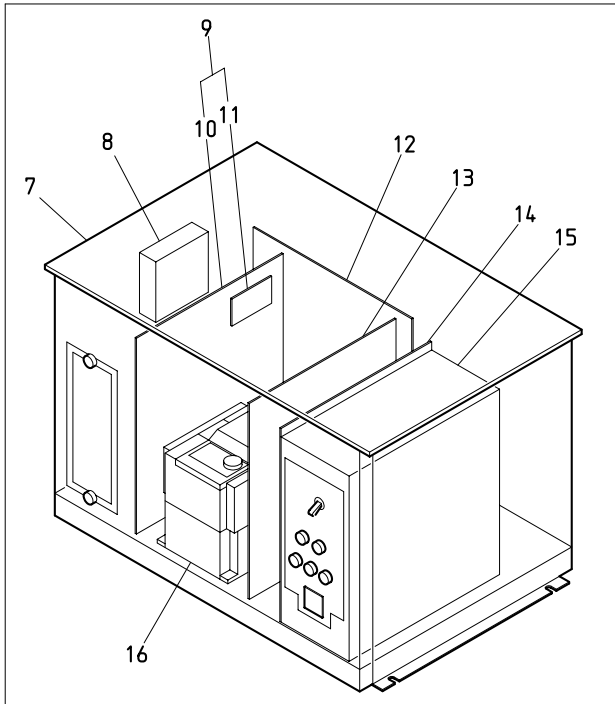
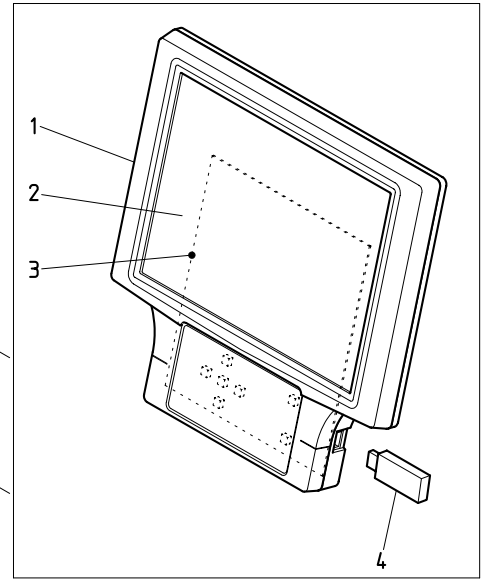
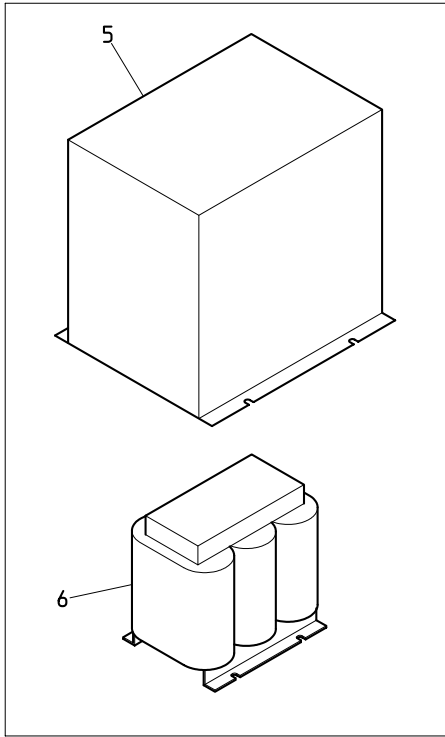

BEKS-Y9 BEKS-Y9H

11A-1-2 Control A (KS2)
制御A (KS2)

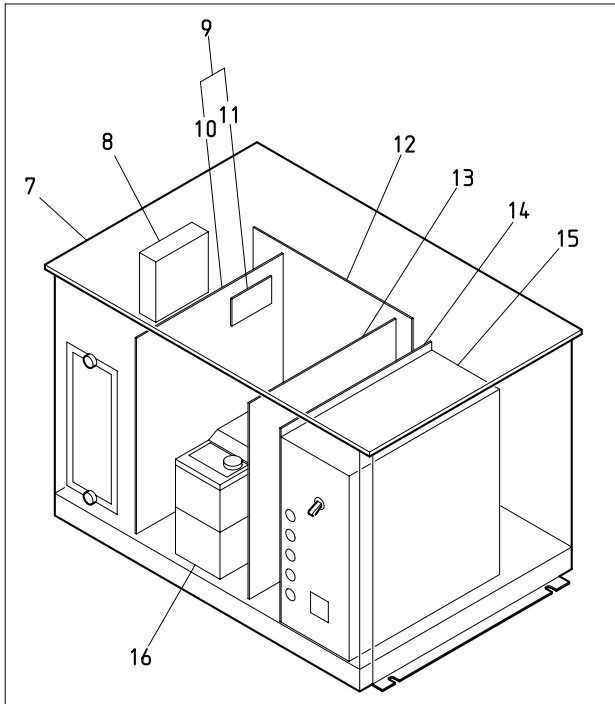
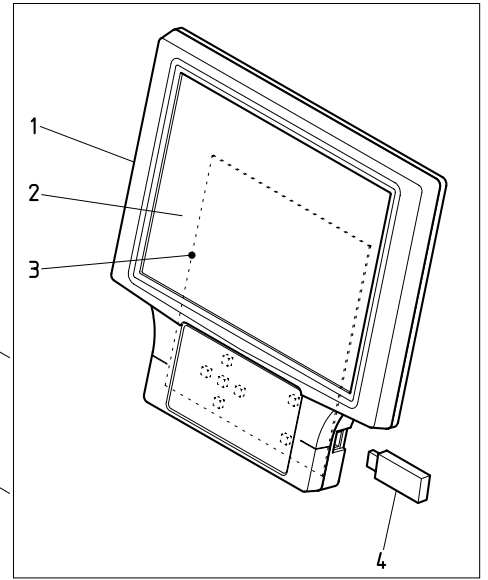
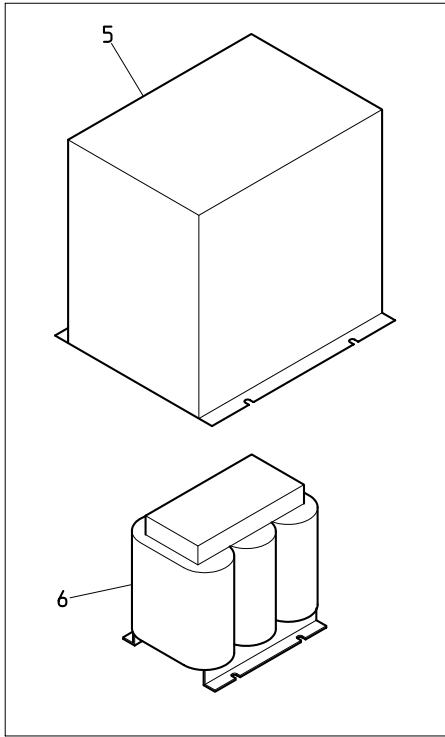

BEKS-S*C BEKS-S15

11A-2 Control A (KY)
制御A (KY)

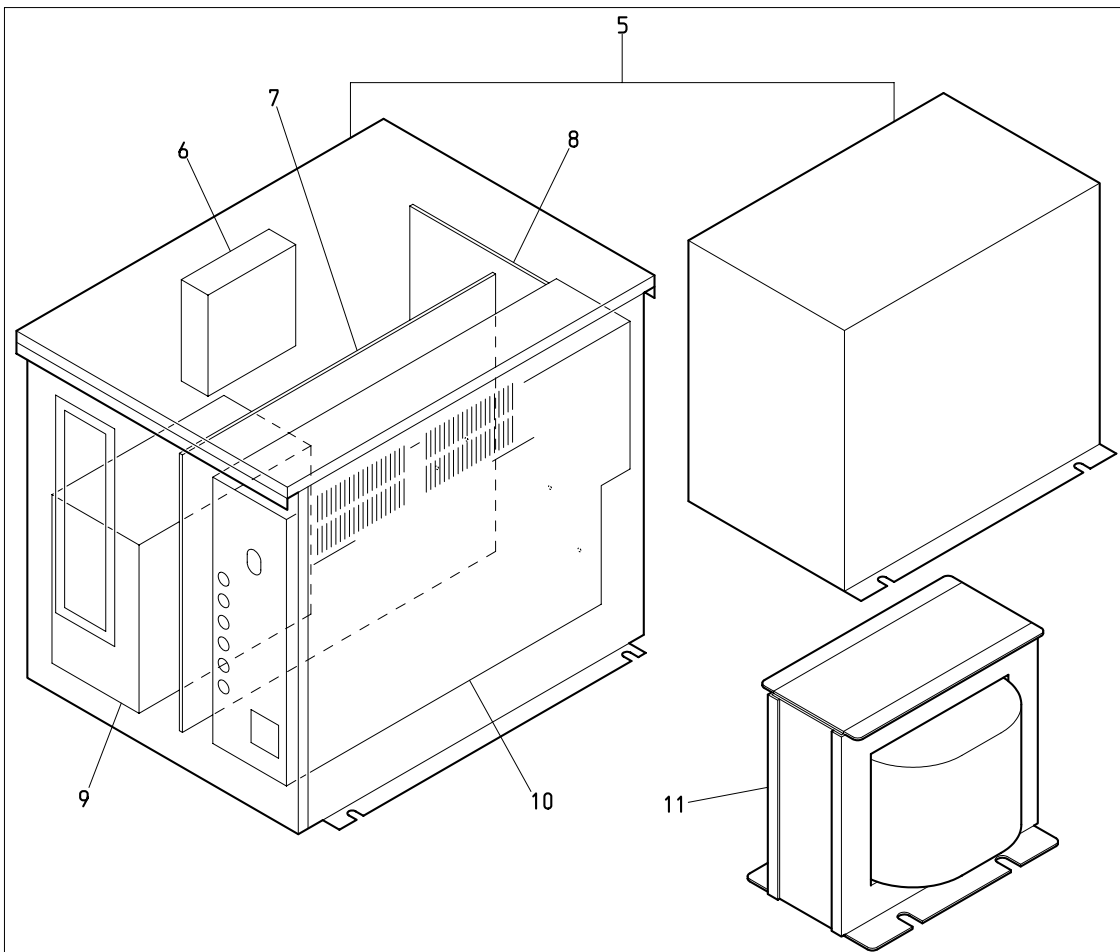
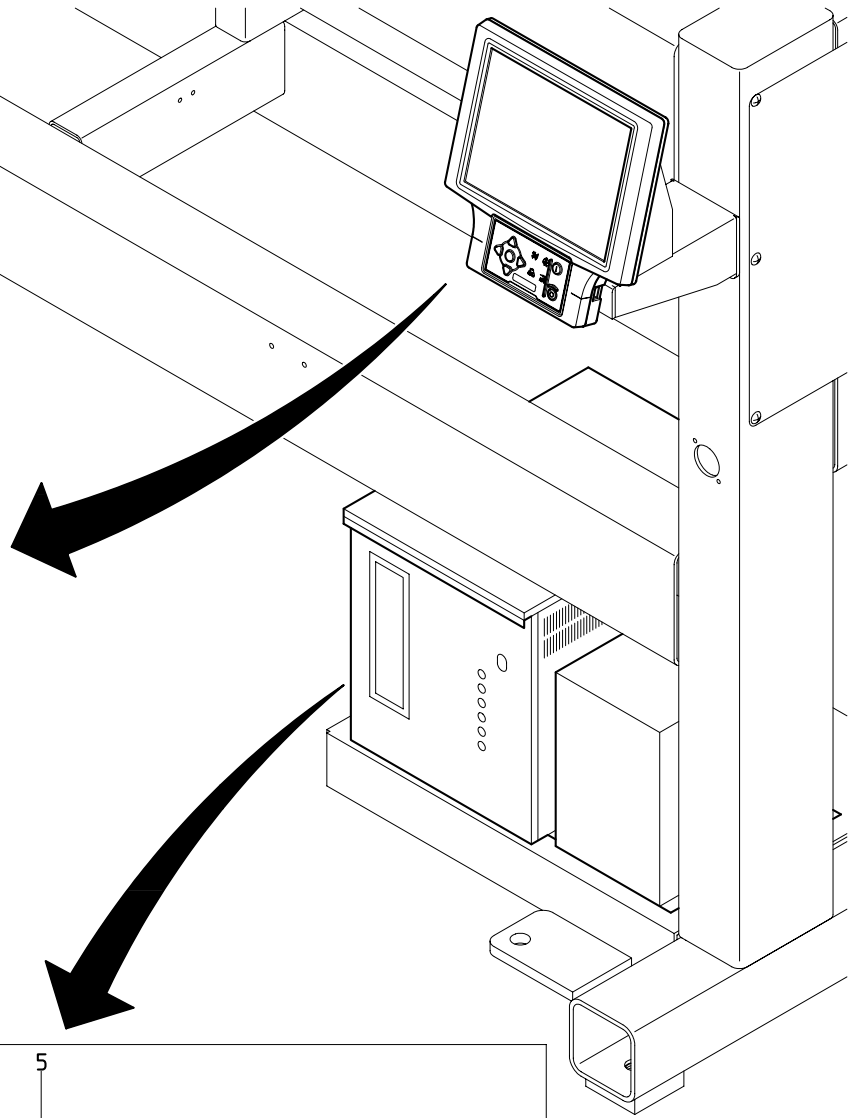
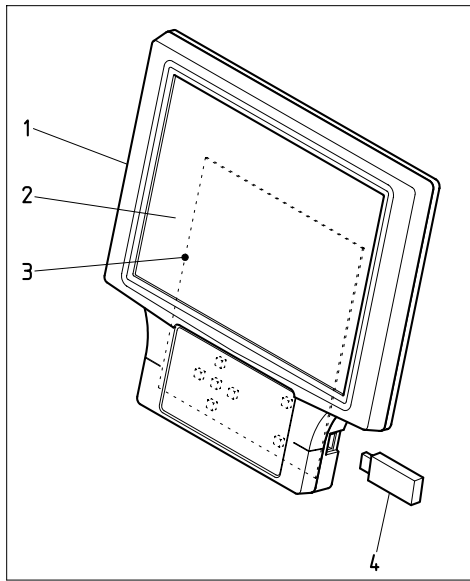

BEKY-S*C11

11B-1 Control B (KS)
制御B (KS)

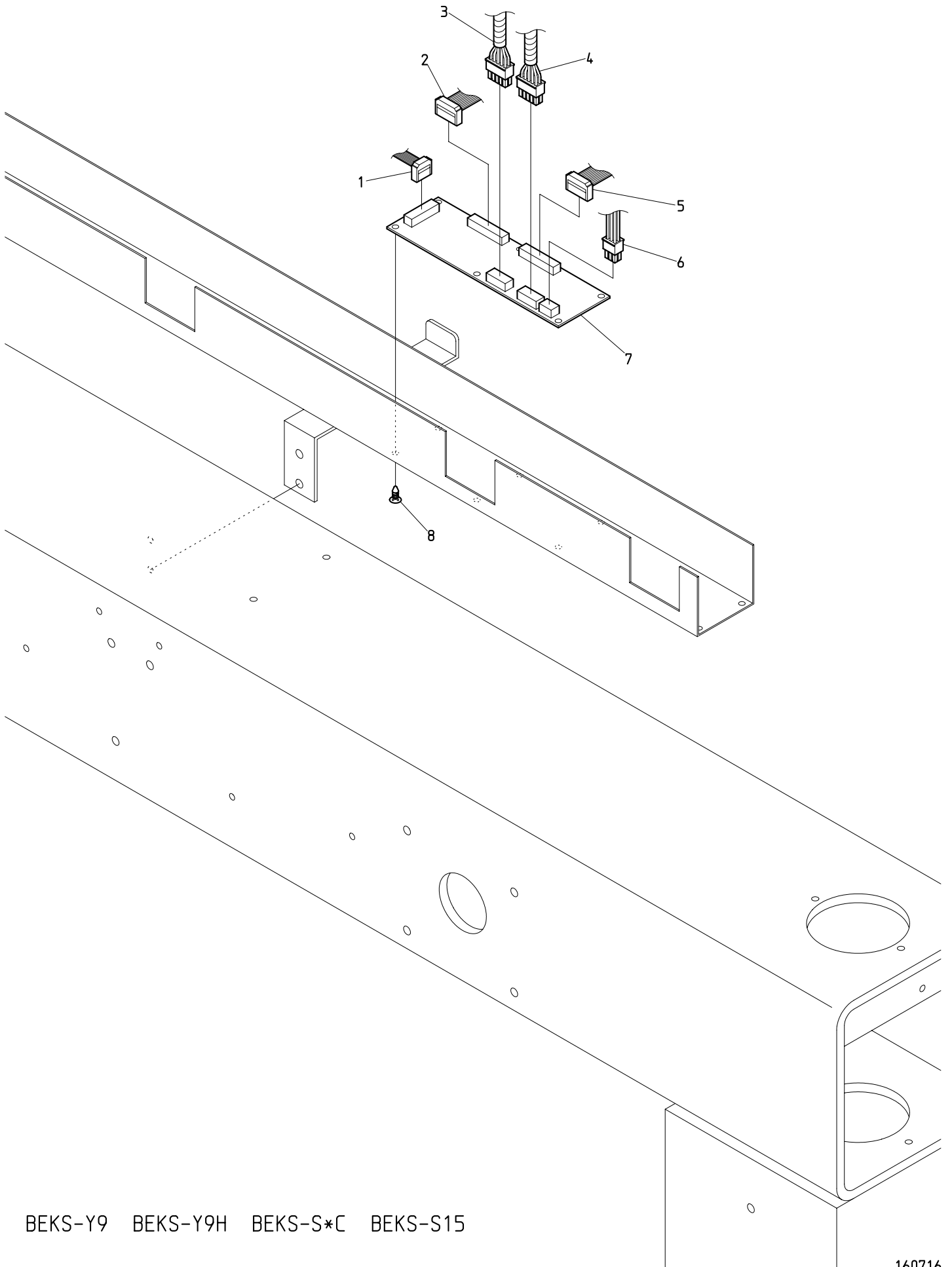

BEKS-Y9 BEKS-Y9H BEKS-S*C BEKS-S15

11B-2-1 Control B (KY,2T/4T)
制御B (KY, 2T/4T)

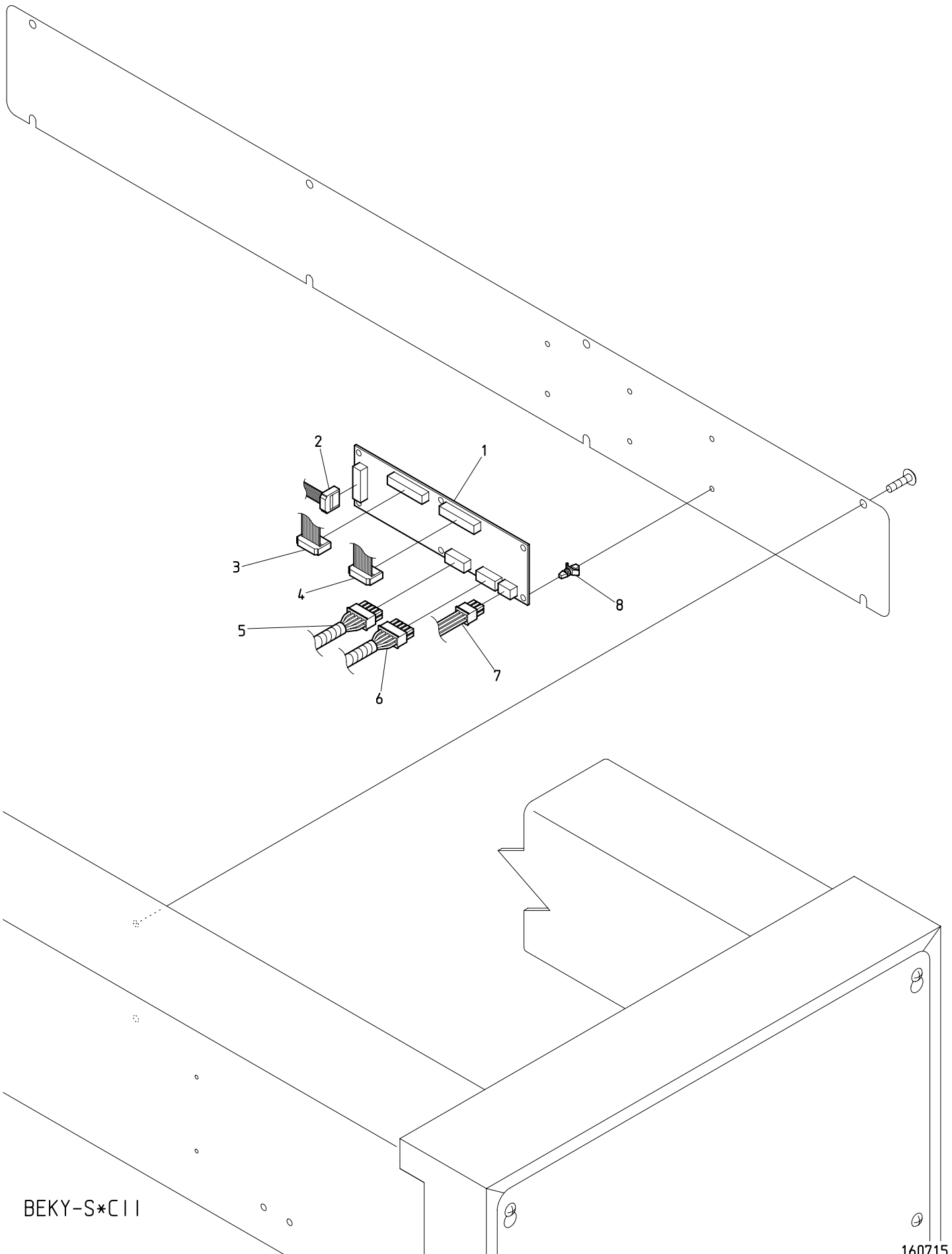

BEKY-S*CI I

11B-2-2 Control B (KY,6T/8T)
制御B (KY・6T/8T)

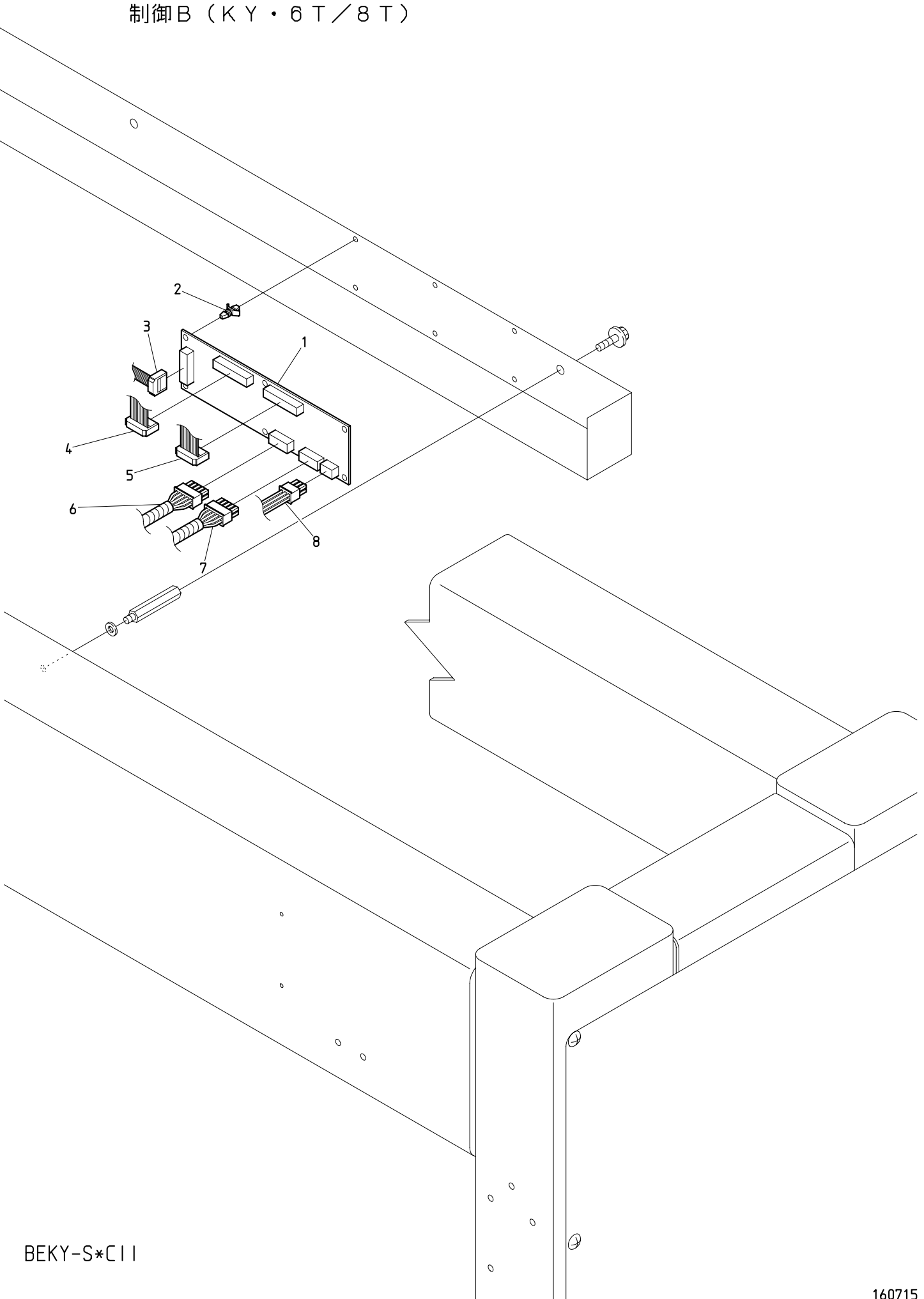

BEKY-S*C11

